

Technical data sheet – Forge welded gratings

Fabrication widths

Fabrication widths SP-gratings at bearing bar thickness 3 mm					
Pitch of bearing bars 34,33; panel width= nominal size 1000 mm					
Number of bars	Grating width	Number of bars	Grating width	Number of bars	Grating width
2	39 mm	12	382 mm	22	726 mm
3	73 mm	13	417 mm	23	760 mm
4	108 mm	14	451 mm	24	794 mm
5	142 mm	15	485 mm	25	829 mm
6	176 mm	16	520 mm	26	863 mm
7	211 mm	17	554 mm	27	897 mm
8	245 mm	18	588 mm	28	932 mm
9	279 mm	19	623 mm	29	966 mm
10	314 mm	20	657 mm	30	1000 mm
11	348 mm	21	691 mm		

All mentioned dimensions are theoretical and include normal production tolerances

Types of forge-welded gratings

Types of forge-welded gratings				
Example SP 330 - 34/38 - 3				
Forge-welded grating	SP			
Bearing bar \varnothing 30 x 3 mm		330		
Pitch 34 x 38 mm			-34/38	
Banding \varnothing 30 x 3 mm				-3
Type	SP	330	-34/38	-3
Type as above, but Pitch 34 x 50 mm			-34/50	
Type	SP	330	-34/50	-3
Serrated type no. 1 and 11				

Forge welded gratings – Heavy duty gratings

DIN 1055-5/A1

Extract from DIN 1055-5/A1 Fork lift – standard vehicle						
Allowable total weight	Nominal load capacity	Static axial load (standard load) P	Central trace width a	Total width b	Total width l	Uniformly distributed Traffic load (standard load)
kN	kN	kN	m	m	m	kN/m²
25	6	20	0,8	1	2,4	10
35	10	30	0,8	1	2,8	12,5
70	25	65	1	1,2	3,4	15
130	50	120	1,2	1,5	3,6	25

DIN 1072

Extract from DIN 1072			
Oscillation value	Bridge class ¹	Wheel load	Load area ²
If traffic lane contains construction parts that are particularly susceptible to localised brake loading (e.g. parts of traffic lane crossings, gratings, etc.), wheel load should be multiplied by 1,4 to determine brake loading occurring on single parts	60	100 kN	200 x 600 mm
	45	75 kN	200 x 500 mm
	30	50 kN	200 x 400 mm
	24	40 kN	200 x 300 mm
	16	50 kN	200 x 400 mm
	12	40 kN	200 x 300 mm
	9	30 kN	200 x 260 mm
	6	20 kN	200 x 200 mm
	3	10 kN	200 x 200 mm

¹ Bridge class = total weight of the vehicle; ² Load area = Load contact area

Forge-welded gratings - serrated

Remarks concerning serration

Reduction of load bearing capacity on gratings

In order to increase levels of slip resistance, bars are serrated by punching out material from walking surface. Due to this reduction in material, the load values stated in the load tables for non serrated walking surfaces need to be reduced proportionately. The load bearing capacity of serrated grating types no. 1, no. 3 und no. 31 is reduced by approx. 24% for forge-welded gratings and pressure-locked gratings having 20 x 2 mm bearing bars and by approx. 9% for 60 x 5 mm bearing bars. At the reduced loading on 20 x 2 mm bearing bars, the deflection is approx. 17% greater and on 60 x 5 mm bearing bars, it is approx. 4% greater.

Walkways' having inclines between 6° and 24°

The supply of standard gratings is recommended for walkways to conveyors or similar installations, when they are inclined up to 6°. Walkways inclined from 6° to 10° should be provided with serrated gratings. At an angle of inclination between 10° and 24°, metal gratings should be supplied with an anti-slip metal strip securely fixed to the top surface over the whole length of the grating. For angles of incline in excess of 24°, stairs should be used. The pitch of anti-slip strips is to be determined from the formula used for stair design, which is $600 \leq g + 2h \leq 660$, where g = the stairtread 'going' and h = the height determined from the angle of incline.

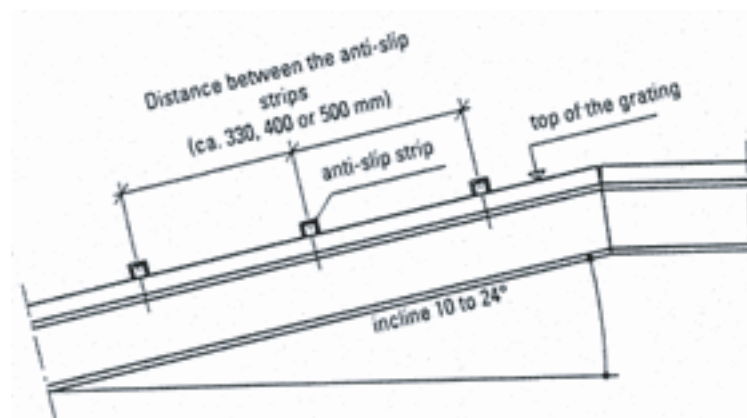

Test results of serration

Gratings and perforated metal planks used as self-supporting floor coverings

Basis of the tests: Instruction sheet ZH 1/571 for flooring in working rooms and working areas where there is a potential slipping hazard. Tests have been done by the "Berufsgenossenschaftliches Institut für Arbeitsschutz – BIA, St. Augustin

The following table shows the test results of Lichtgitter products.

Type	Serration No.	Surface treatment	Pitch (mm)	Serration class	Displacement
Gratings out of steel S235JR					
SP 330-34/38-3	-----	galvanized	34x38 mm	R 10	V 10
P 330-33-3	----	galvanized	33x33 mm	R 10	V 10
P 230-33/11-3	----	galvanized	33x11 mm	R 9	V 10
XSP 330-34/38-3	1	galvanized	34x38 mm	R 10	V 10
XSP 330-34/38-3	11	galvanized	34x38 mm	R 11	V 10
XP 230-33-3	2	galvanized	33x33 mm	R 12	V 10
XP 230-33/22-3	2	galvanized	33x22 mm	R 12	V 10
XP 230-33/11-3	2	galvanized	33x11 mm	R 12	V 10
XP 430-33-4	2	galvanized	33x33 mm	R 11	V 10
XP 330-33/22-3	22	galvanized	33x22 mm	R 12	V 10
XP 230-33-3	22	galvanized	33x33 mm	R 13	V 10
XP 330-33-3	22	galvanized	33x33 mm	R 12	V 10
XP 230-33-3	3	galvanized	33x33 mm	R 11	V 10
XP 330-33-3	3	galvanized	33x33 mm	R 11	V 10
XP 230-33-3	31	galvanized	33x33 mm	R 12	V 10
XP 330-33-3	31	galvanized	33x33 mm	R 12	V 10
XP 430-33-4	31	galvanized	33x33 mm	R 11	V 10
XP 530-33-5	31	galvanized	33x33 mm	R 11	V 10
XP 330-44-3	31	galvanized	44x44 mm	R 12	V 10
XP 230-33/11-3	32	galvanized	33x11 mm	R 10	V 10
XP 230-33/11-3	4	galvanized	33x11 mm	R 11	V 10
XP 230-33-3	4	galvanized	33x33 mm	R 11	V 10
XP 330-33-3	4	galvanized	33x33 mm	R 11	V 10
XP 430-33-4	4	galvanized	33x33 mm	R 11	V 10
XP 530-33-5	4	galvanized	33x33 mm	R 11	V 10
XP 230-33/11-3	42	galvanized	33x11 mm	R 10	V 10
XP 230-33-3	42	galvanized	33x33 mm	R 11	V 10

Gratings out of stainless steel

XP 225-33-3	3	pickled	33x33 mm	R 12	V 10
XP 225-33-3	31	pickled	33x33 mm	R 13	V 10
XP 325-33-3	31	pickled	33x33 mm	R 12	V 10
XP225-25-3	31	pickled	25x25 mm	R 13	V 10
XP 325-25-3	31	pickled	25x25 mm	R 12	V 10
XP 525-25-5	31	pickled	25x25 mm	R 12	V 10

XP 525-33-5	31	pickled	33x33 mm	R 12	V 10
-------------	----	---------	----------	------	------

Gratings out of Aluminium AlMg 3G22

XP 225-33-3	3	pickled	33x33 mm	R 13	V 10
XP 225-33-3	31	pickled	33x33 mm	R 13	V 10
XP 225-33-3	4	pickled	33x33 mm	R 13	V 10

Perforated metal planks out of steel S235JR

BR 50/2		galvanized	rhombic	R 11	V 10
BP 50/2		galvanized	parallel	R 11	V 10
BP-Ü 50/2		galvanized	parallel raised	R 12	V 10
BN-G 50/2		galvanized	closed	R 9	
BN-O 50/2		galvanized	open	R 11	V 10
BZ 50/2		galvanized	tooth	R 11	V 10
BP 50/2		*see below	parallel	R 11	V 10
BZ 50/2		* see below	tooth	R 13	V 10
BN-G 50/2		* see below	closed	R 9	
BN-O		* see below	open	R 11	V 10
BN-G		galvanized sanded with quartz	closed	R 12	

* Continuously hot dipped material quality DX51D+Z200 MAC acc. to DIN EN 10327

Perforated metal planks out of stainless steel

BP 50/2		pickled	parallel	R 11	V 10
BN-O 50/2		pickled	open	R 11	V 10
BZ 50/2		pickled	tooth	R 12	V 10

Perforated metal planks out of Aluminium AlMg 2G22

BP 50/2		pickled	parallel	R 11	V 10
BN-O 50/2		pickled	open	R 11	V 10
BZ 50/2		pickled	tooth	R 13	V 10

GRP-gratings our of UP-GF

GRP-K 630-19-6			concave	R 13	V 10
GRP-K 538-38-6			concave	R 13	V 10

GRP-gratings out of UP-GF with quartz sand 05-1,0 mm

GFK-K 638-38-6			sanded	R 12	V 10
----------------	--	--	--------	------	------

Forge-welded stairtreads

Standard stairtreads acc. to DIN 24531-1

Standard stairtreads acc. to DIN 24531-1							
Type	Bearing bar	Dimension	b	c	d	e	kg/tread
SP 330-34/38-3 Nominal mesh approx. 30 x 30 mm	30 x 3 mm	600 x 240 mm	55	70	120	85	6,0
		600 x 270 mm	55	70	150	85	7,5
		600 x 305 mm	55	70	180	90	10,0
		800 x 240 mm	55	70	120	85	8,0
		800 x 270 mm	55	70	150	85	9,0
		800 x 305 mm	55	70	180	90	11,5
		1000 x 240 mm	55	70	120	85	9,5
		1000 x 270 mm	55	70	150	85	10,5
		1000 x 305 mm	55	70	180	90	13,0
SP 340-34/38-3 Nominal mesh approx. 30 x 30 mm	40 x 3 mm	800 x 240 mm	55	70	120	85	8,0
		800 x 270 mm	55	70	150	85	9,0
		1000 x 240 mm	55	70	120	85	10,0
		1000 x 270 mm	55	70	150	85	11,0
		1200 x 240 mm	55	70	120	85	13,0
		1200 x 270 mm	55	70	150	85	15,5
		1200 x 305 mm	55	70	180	90	18,0

Load instructions

Load instructions acc. to DIN EN ISO 14122-3

Steps shall resist the following unfactored loadings:

If the width "w" < 1200 mm, then 1,5 kN shall be distributed over an area of 100 x 100 mm where one boundary is the leading edge of the nosing, applied at the middle of the stair width. If the width "w" ≥ 1200 mm, then respectively 1,5 kN shall be distributed simultaneously over each of the 100 x 100 mm areas applied at the most unfavourable points, spaced at intervals of 600 mm, where one boundary is the leading edge of the nosing.

The deflection of the supporting structure and the stairs does not exceed under load 1/300 of the span, maximum 6,0 mm

Requirements

Requirements for stairs made out of steel (DIN EN ISO 14122-3)

The rise “h” and going “g”, shall meet the formula, $600 \leq g + 2h \leq 660$. The overlap, “r” of step or landing shall be ≥ 10 mm. The length of landing “l” shall be at least 800 mm and in any case \geq the width of the stair, “w”.

On the same flight, the rise shall be constant wherever possible. In the case where it is not possible to maintain the height of the rise between the level of departure and the lower step, it may be reduced by a maximum of 15%.

H = Climbing height, r = Overlap, g 0 Going, α = Angle of pitch, e = Headroom, w = Width, h = Rise, p = Pitch line, l = Length of landing, t = Height of step, c = Clearance

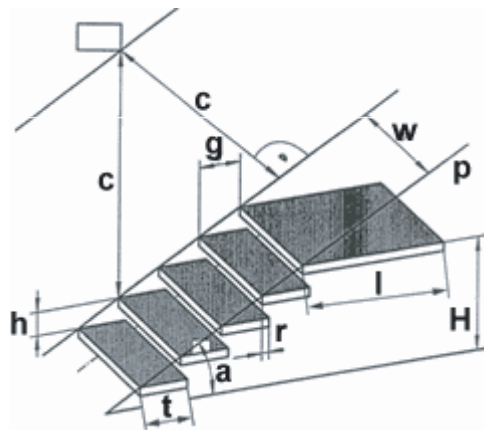

Forge-welded gratings

Surface treatment

Surface treatment for steel gratings and steel for construction applications, in accordance with to DIN EN 10025

- Galvanizing acc. to DIN EN ISO 1461 (hot dip galvanized)
- Galvanized followed by bitumen dipping
- Plastic coating *, also on galvanized surfaces (colours according to RAL)
- Baked paint*, also on galvanized surfaces (colours according to RAL)

Gratings and perforated metal planks made of stainless steel, material acc. to DIN 17440

- Pickled
- Electrochemically polished
- Glass bead blasting

Gratings and perforated metal planks from aluminium, material acc. to DIN EN 485 and DIN EN 573

- Pickled
- Baked paint* (colours according to RAL)
- Anodised
- Plastic coating* (colours according to RAL)

* A coating with epoxy resin powder for outside areas is not recommended. For these areas, a polyester powder coating should be used.

Gratings and perforated metal planks receive a surface protection to avoid potential corrosion.

Gratings manufactured from stainless steel and aluminium generally do not need a corrosion protection. At least one after-treatment by pickling or anodising is recommended.

Hot dip galvanizing (usual corrosion protection for gratings)

The term "hot dip galvanizing" means the adding of a zinc finish by dipping the pre-treated parts into a molten zinc dip. The zinc coat adheres firmly to surfaces. In case of normal mechanical demands such as transportation, pedestrian or vehicle traffic, zinc does not flake off or develop cracks.

The average weight of the zinc coating is approximately 450 g per sqm of treated surface. This corresponds to a coating thickness of approximately 65 µm. The thickness of the zinc coating also depends on the thickness of the material. Before galvanizing, parts are pre-treated to provide a mechanically clean surface in order to achieve a faultless adherence of zinc.

Bitumen dipping is often requested as an additional treatment for galvanized gratings, and gives extra surface protection (mainly for chemical use).

Plastic coatings are achieved, e.g. by dipping or electrostatic powder coating. The abrasion resistance and thickness of finish required, depends upon the application, so this need to be considered when deciding which procedure and plastic to use.

Painting

Gratings and perforated metal planks can likewise be lacquered in a dipping or spraying process, preferably after galvanizing.