



Lichtgitter – Always close to the wind

Our products in the offshore wind power industry



-
- A An International Group of Companies**
with offshore competence
 - B Product variety of Lichtgitter**
Everything from one source
 - C Lichtgitter Offshore Product overview**
Offshore-Solutions at a glance
 - D Lichtgitter Offshore**
All products and applications in detail
 - E Lichtgitter Service**
Your All-Inclusive-Package
 - F Lichtgitter Contact**
We are glad to assist you personally!

A

Lichtgitter – International Group of Companies with offshore competence



Lichtgitter – Everything from one source



Well-known references all over the world

Lichtgitter – well positioned worldwide: A bright outlook since 1929

Lichtgitter was established in 1929 in order to carry out the specialized manufacturing of gratings. By the continuous monitoring of our performance, and quality systems, together with innovation in manufacturing techniques, we have ensured Lichtgitters place in the forefront of manufactures of forge-welded gratings, pressure-locked gratings and perforated metal planks worldwide. Our current product range also includes the distribution of GRP-gratings, profiled chequer plates, spiral staircases, straight staircases

and ladder rungs. Together with our steel slitting service centre and hot dip galvanizing plant we provide a complete fabrication facility to our customers. Lichtgitter is certified to DIN EN 9001:2008, and complies with all European and International Standards.



Head Office Stadtlohn, Germany



Here you will come to B:
Product variety of Lichtgitter
Everything from one source

B

Product variety of Lichtgitter: Everything from one source And what can we do for you?

Gratings

In addition to forge-welded gratings, which are characterized by an excellent loadbearing capacity and torsional rigidity coupled with a non-slip factor due to the twisted cross bars, Lichtgitter also produces a lot of types of pressure-locked gratings. Pressure-locked gratings are

made of steel, stainless steel and aluminium.

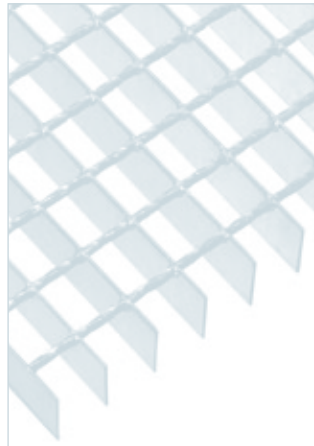

Forge-welded grating

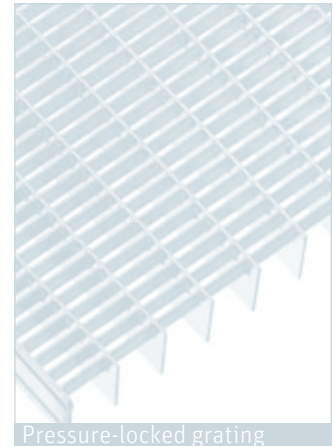

Pressure-locked grating with narrow pitches

Chequer Plates

Chequer plates are often used in the offshore area as a floor covering. Due to the structure the flooring with its closed surface is slip resistant even in presence of oil and grease. The rate of wear seen over years is relatively low.



Chequer Plate

Here you will come to C:

[Lichtgitter Offshore Product overview](#)
[Offshore-solutions at a glance](#)



GRP-gratings

The Lichtgitter Group has produced and distributed a range of GRP-gratings since the early 90s. The GRP-gratings are especially used as floor coverings in the offshore area due to their corrosion resistance and long durability. GRP-gratings are easily adaptable to complex structures and shapes

also the ability to achieve a serration class R13 according to BGR 181. Another advantage of GRP-products is the low weight to span ratio.



GRP-grating

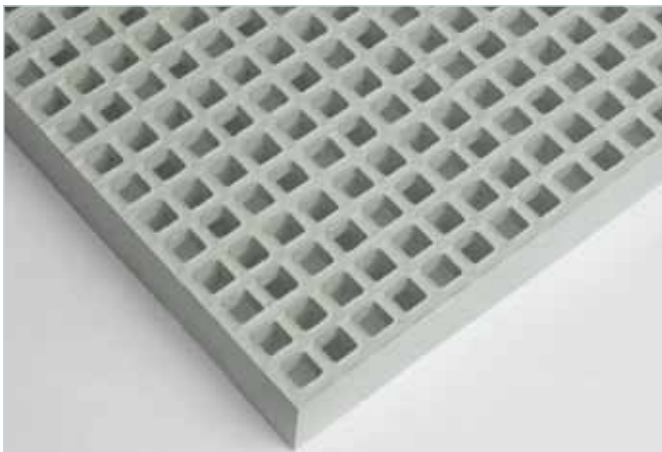

Micro mesh GRP-grating



GRP-grating with closed gritted surface

Perforated metal planks

Perforated metal planks distinguish themselves by providing a high level of slip resistance and comfort to standing areas. Large spans can be achieved, thus minimizing the use of steel substructures. Perforated metal planks can be manufactured in variety of surface patterns. The flame resistant

covering BN-OF is based on the perforated metal plank type BN-O and is used as a transformer covering on transformer stations.

Are you interested in our products?
Visit us online at www.lichtgitter.de



Perforated-metal plank, Type BN-O



Blechprofilrost Typ BP

C

Lichtgitter Offshore Product overview Offshore-Solutions at a glance

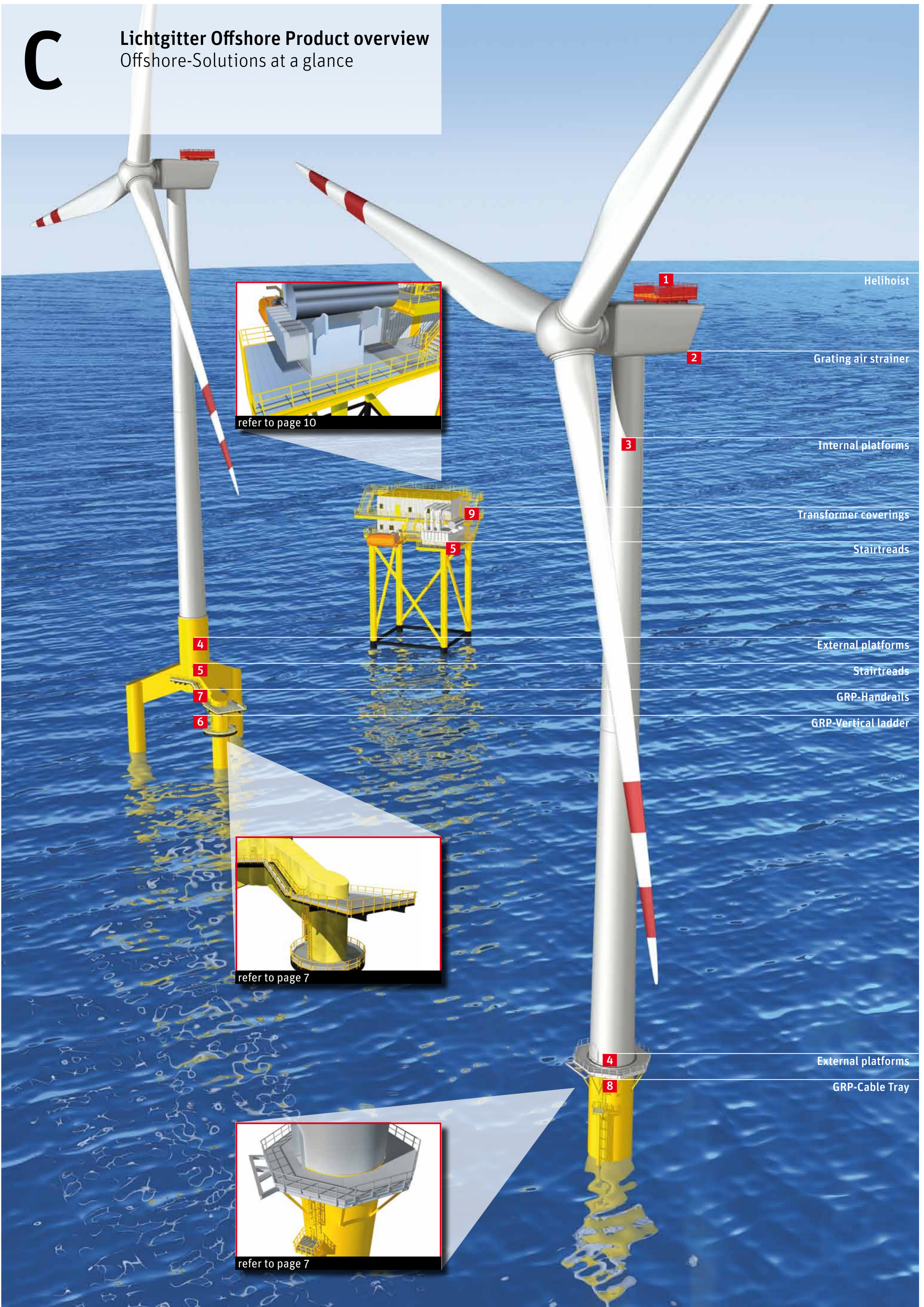

Helihoist

Grating air strainer

Internal platforms

Transformer coverings

Stairtreads

External platforms

Stairtreads

GRP-Handrails

GRP-Vertical ladder

External platforms

GRP-Cable Tray



refer to page 10



refer to page 7



refer to page 7



Lichtgitter –Your competent offshore partner



Intermediate platform made from chequer plates

Lichtgitter Offshore Quality at all levels

We are experienced in the high demands of offshore construction and the requirements to ensure on-time deliveries, to enable tight programmes to be met. This challenge to ensure exceptional quality and logistical needs is where Lichtgitter scores with fully integrated service of products and systems. Our computer supported CAD/CAM production and manufacturing system grant high quality and satisfied customers.

True to the motto “Lichtgitter – Everything from one source” we offer you the range to meet your wind energy plant requirements with all types of industrial floor coverings. Whether platforms of gratings or chequer plates or transformer coverings to the point of helihoist, we give you an all-inclusive package backed-up by the established Lichtgitter

quality. Due to our long lasting experience you can be assured that we will ensure quality and safety at all levels. The advantage of our complete offering is that you can discuss everything with one supplier and that you get all the product-related services like support during the planning period, preparation of layout-drawing, completion of the technical documentation from one source.



GRP-gratings used in offshore area

D

Lichtgitter Offshore – All products and applications in detail



Helihoist

1 Helihoist

The helicopter platforms are made of GRP-gratings and – profiles. Even at poor weather conditions it is possible to set up persons via helicopter. The platforms are distinguished not only for the usual properties of GRP-products, they have a low maintenance and high durability too. Furthermore solutions concerning the static charge are available.



Possible basic structure of a helihoist



Temporary build at the plant

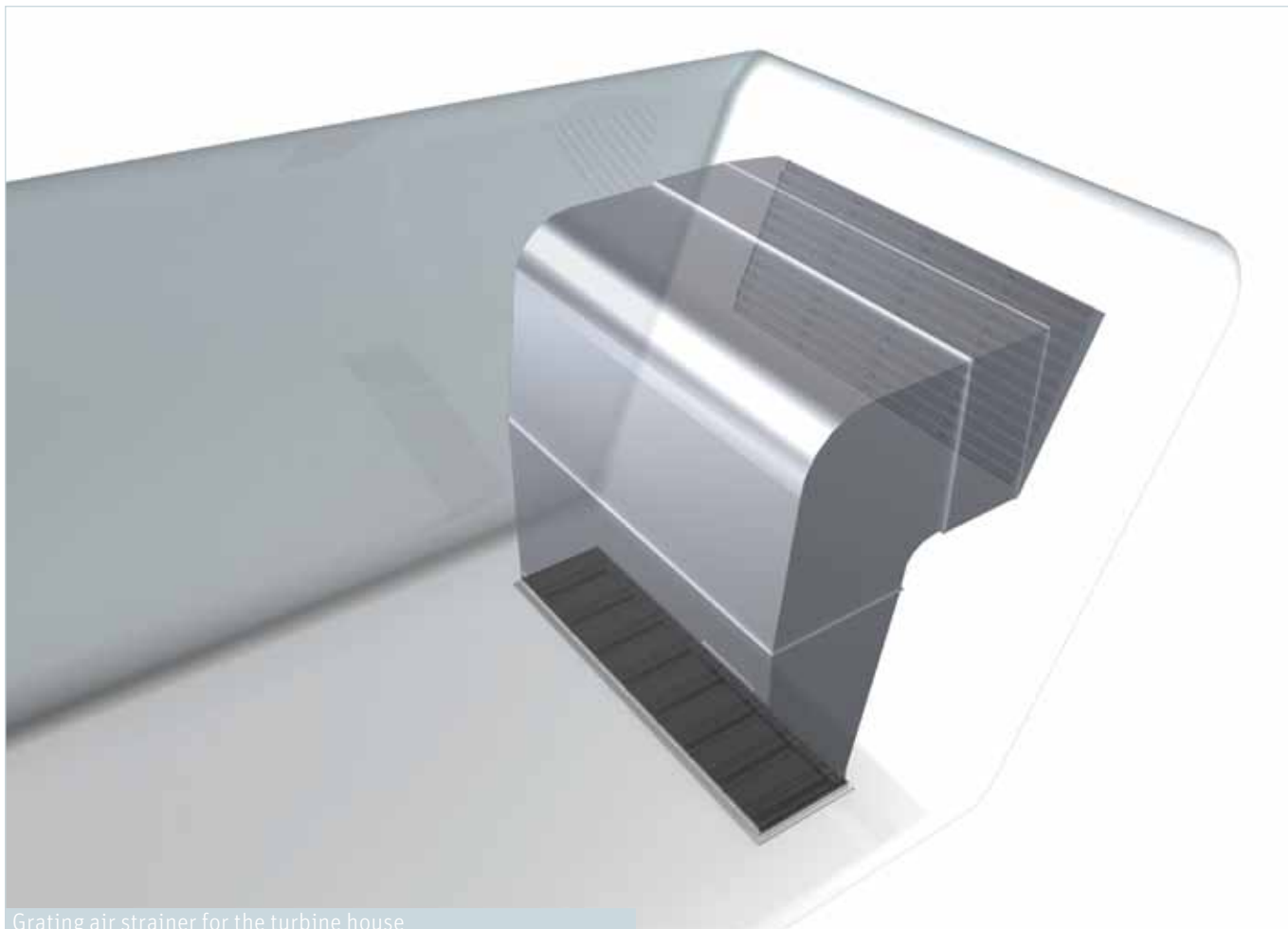

Grating air strainer for the turbine house

2 Grating air strainer

For the cooling of the oil inside the engine room, air from the environment is running via an air strainer to the oil cooler. With the help of a special “sandwich” flooring of duplex coated pressure-locked gratings it is possible to get access and to maintain the units. Filter fleece and counter bearings are within a single component.

The filter can be replaced relatively easily without additional safety measures. This reduces the maintenance costs.

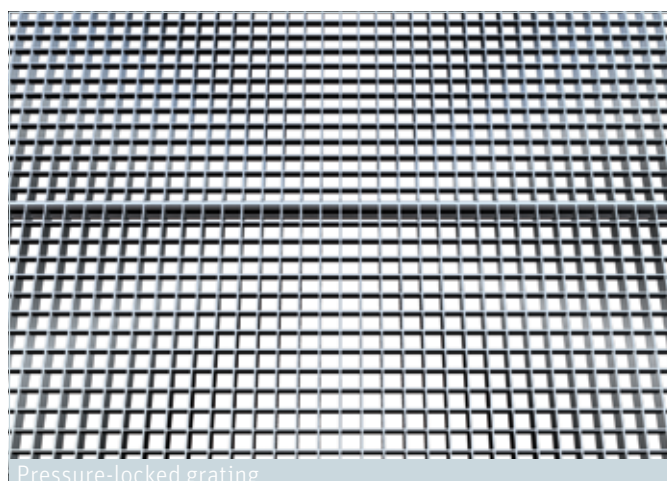

Pressure-locked grating

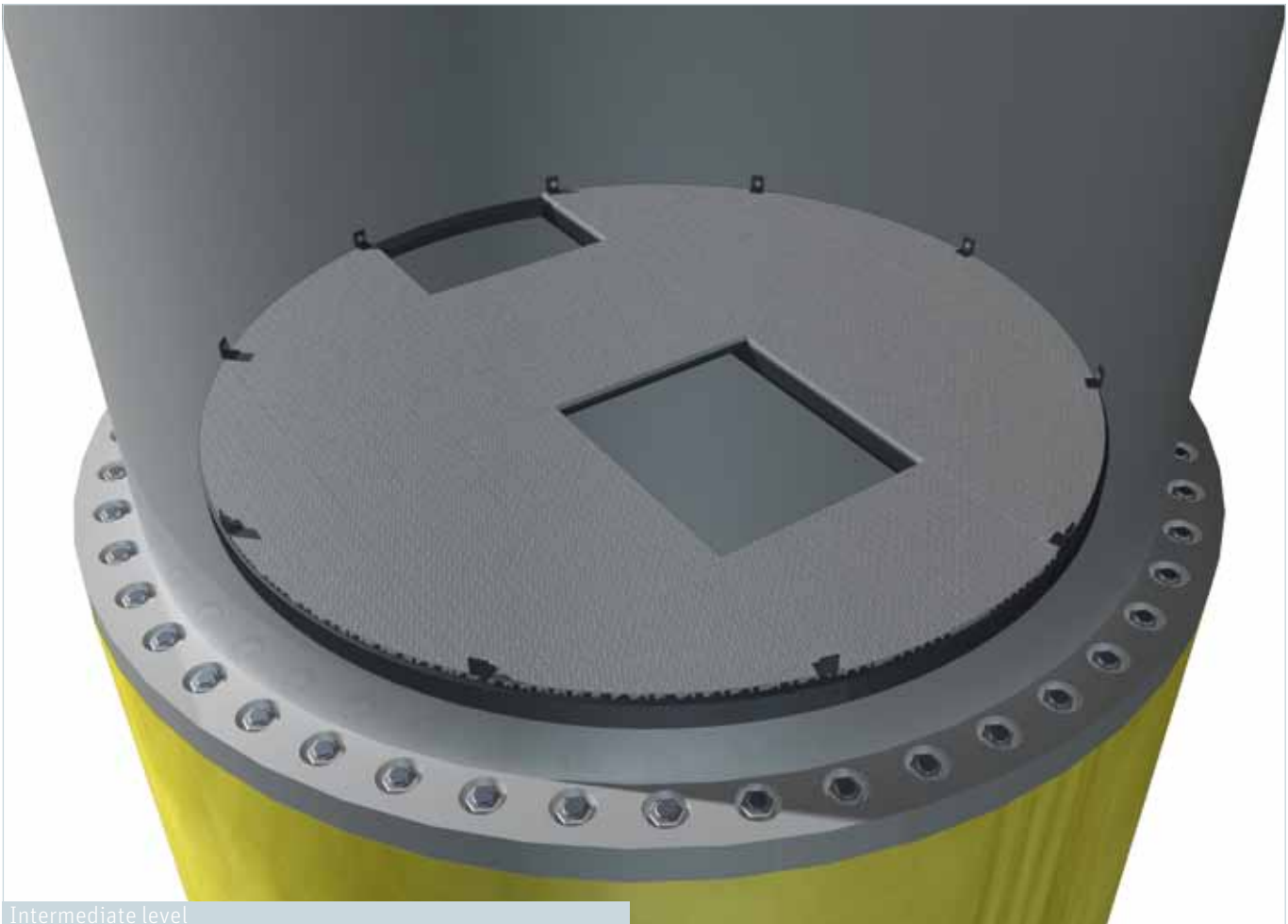

Intermediate level

3 Internal platforms

The internal platforms in the tower of the windmill can be arranged with different floorings. Industrial floor coverings are specially qualified for this. In addition to the established range of gratings like forge-welded gratings and pressure locked gratings in steel, stainless steel and aluminum, we also can supply perforated metal planks in a variety of surface patterns, GRP-gratings or chequer plates.



Intermediate level made from GRP-gratings



Intermediate level made from chequer plates



External platform at the tripile



External platform at the monopile



Laying of a platform for testing at the work

4 External platforms

The external platform is located at the bottom of the windmill and is used for parking of containers and materials which are needed for maintenance.

On this maintenance platform different floorings can be used. Often used are gratings made of fiberglass plastic. In addition to GRP-gratings, GRP-handrails and GRP-cable trays can be applied. They are characterized by their weather resistance and their low weight.

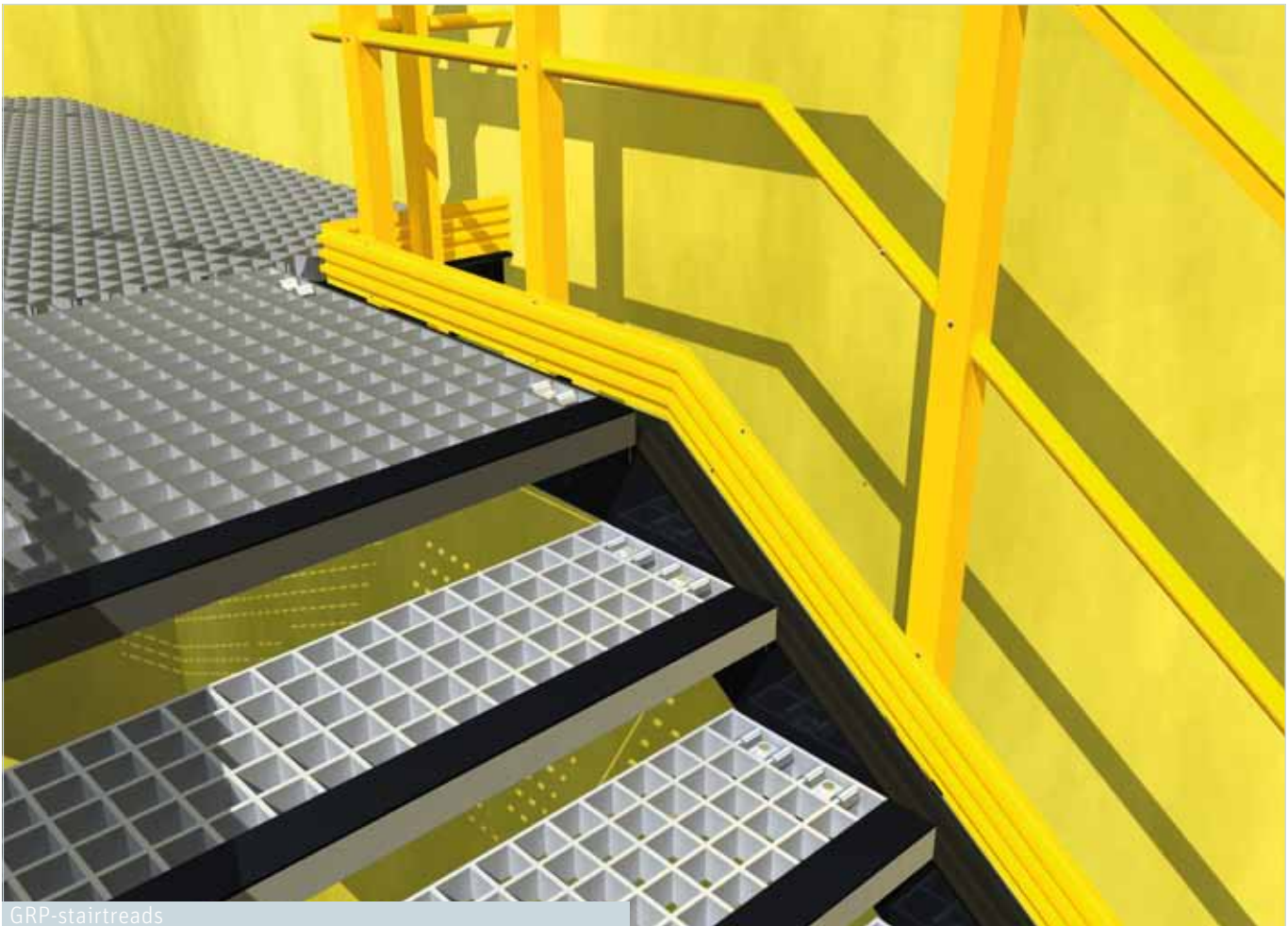

GRP-stairtreads

5 Stairtreads

Pressure-locked-, forge-welded-, perforated metal planks- and GRP-stairtreads are produced in the same grating types as used for platforms and walkways.

Stairtreads of steel are always supplied with serrated, perforated nosing and welded side plates. Perforated nosing increases the anti-slip value of the stairtreads and favourably accentuates the leading edge visually. This is an important contribution to safety. GRP-stairtreads are supplied with a closed, black gritted nosing or

with a GRP black gritted angle as nosing for statical requirements. GRP-stairtreads will normally be supplied without side plates. It is possible to deliver the stairtreads with a side plate made of GRP-angle if required.

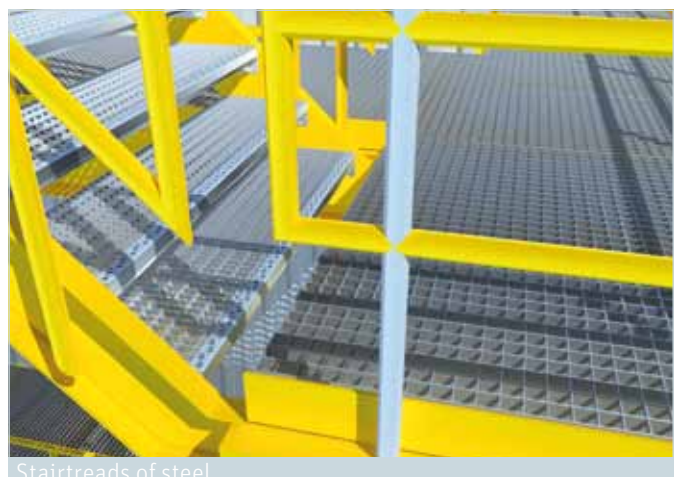

Stairtreads of steel

6 GRP-Vertical ladder

Lichtgitter GRP-Vertical ladders are weather resistant and have durability and light weight. They are made of GRP-profiles according to EN 13706, type E23. The rung-profile (ladder step profile) is slip resistant. At the screwing points of the rungs the GRP-

Vertical ladder will be reinforced by PE materials.



GRP-Railing



GRP-safetycage ladder

7 GRP-Handrails

Lichtgitter GRP handrails are produced from GRP profiles reinforced with glass fibre. They can withstand high loads, are weather resistant and easily to assemble and fit. They can be provided both as horizontal as well as an inclined handrailing system.

8 GRP-Cable Tray

Lichtgitter Cable trays are manufactured on the basis of a high grade resin, strengthened with glass fibres and are weather resistant. They are UV-resistant and have good properties in relation to fire classification. Because of their closed system, they provide good protection for the cables to media and weather influ-

ences. Other advantages of the cable channel system are its low weight and the easy handling and processing of the profiles.

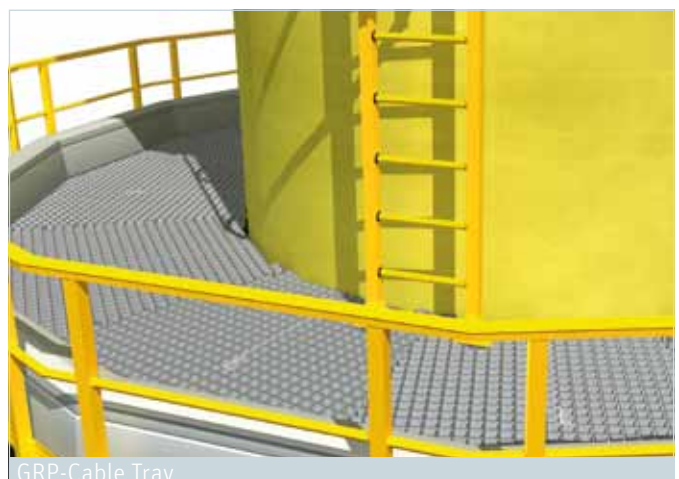

GRP-Cable Tray

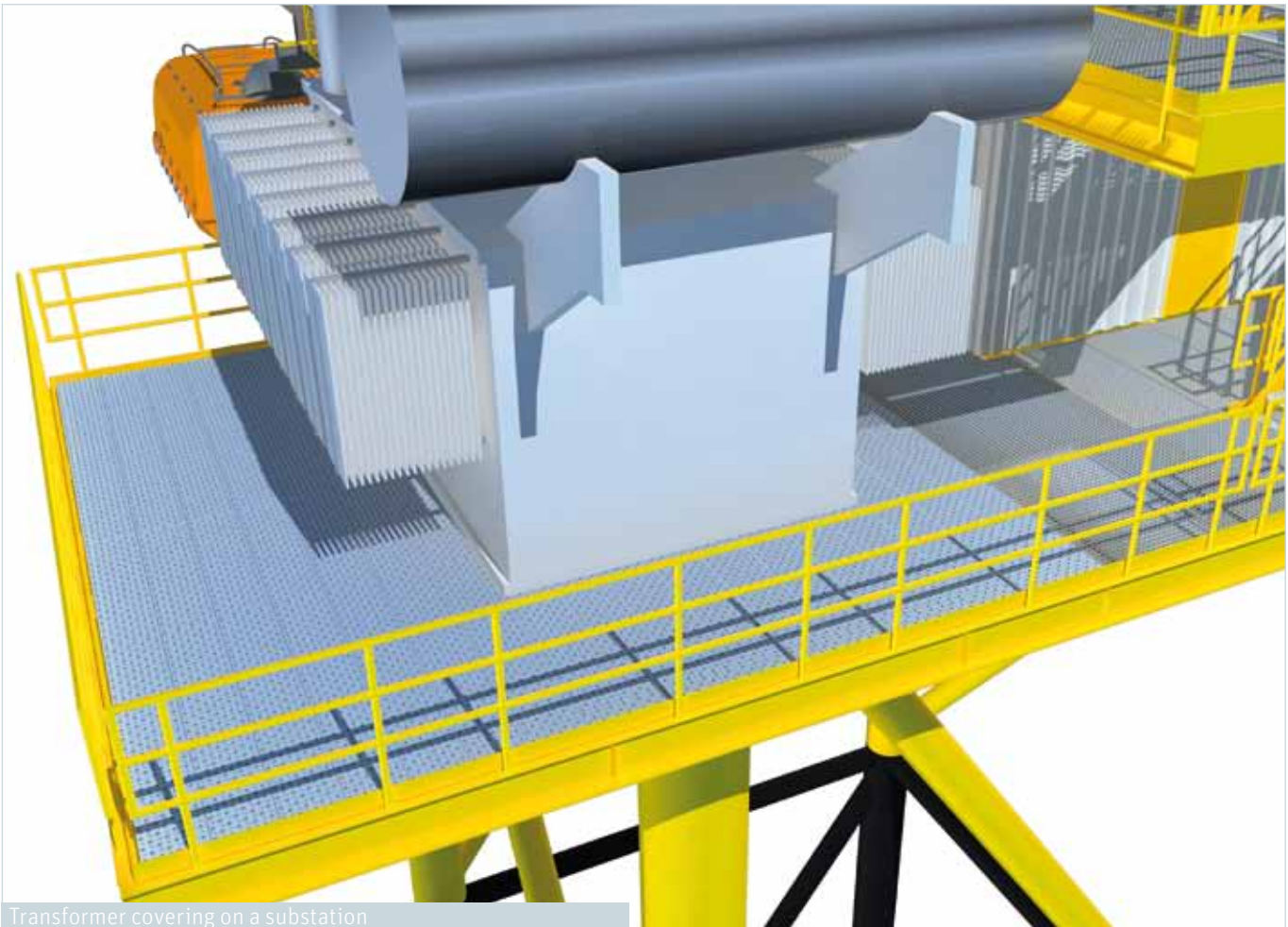

Transformer covering on a substation

9 Transformer coverings

The flame resistant covering BN-OF has gained acceptance as an alternative to the conventional transformer covering with coarse gravel. Due to the limited air permeability the flames are contained and delayed in case of a brand. Even for the transformer in the offshore area the flame resistant covering, which is based on the perforated metal plank type BN-O, form an optimal solution. The BN-O planks have an optimal surface structure and are slip resistant up to the serration class R11 according to BGR 181 due to the unique punched hole pattern. The hole pattern allows an optimal flow rate of oil, fire and rain water. The covering can be assembled and dismantled quickly,

because of its low weight. So, maintenance costs and switch-off costs for the required inspections and closeness tests can be reduced.



Flame resistant covering BN-OF

E

Lichtgitter Service Your All-Inclusive- Package

From planning to delivery

Competent product- and building-linked advice in combination with high technical know-how and expertise – these services are self-evident for us. For us it is a great pleasure to get inquiries which request individual demands and therefore lead to the developing of new application solutions. We offer support regarding the planning, preparation of layout drawings, design and technical documentation. The preparation of packing lists as well as an appropriate packaging and consignment are also part of our services.

Important for our clients is the consistently
: high quality of all of our products and services
: the reliability
: and the competence of the contact persons.
To ensure these requirements the manufacturing of our products is monitored and assessed in accordance with standards and regulations.
In the future, Lichtgitter will address its attention to the permanent improvement of its technical equipment, in order to identify new solutions in areas of industrial floor coverings.

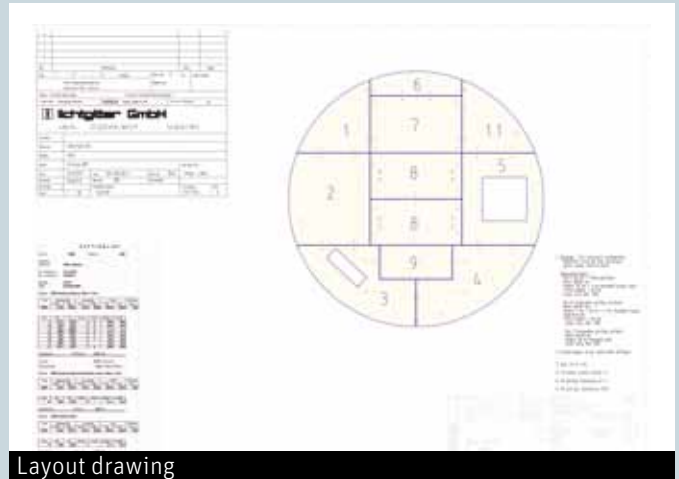

Layout drawing

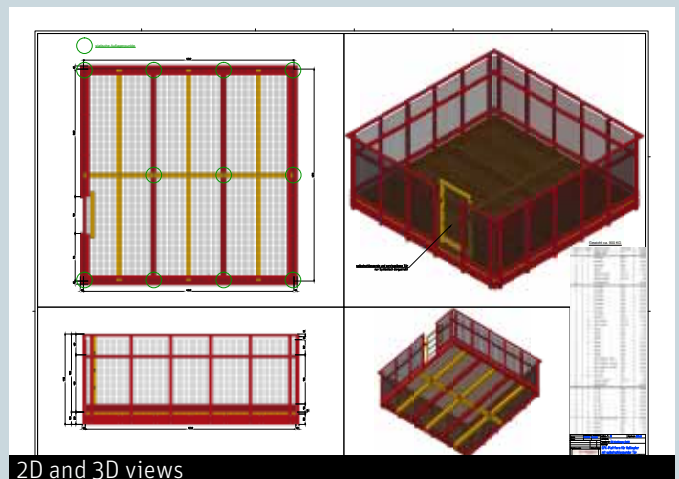

2D and 3D views



Assembly of a platform for testing reasons at works



Packaging and consignment

F

Lichtgitter Contact

With pleasure we assist you personally!
Please contact us.



Subsidiaries

Suomen Teräsrtilä, Finland
Le Caillebotis Diamond,
France
CSE Lichtgitter, France
Lichtgitter UK, Great Britain
Las Pers, Netherlands
Dejo Metaalindustrie, Nether-
lands
Lichtgitter Service Center
OTW, Austria
Stegerud Steel, Sweden
Lichtgitter Anton Ruppli,
Switzerland
Lichtgitter Slovakia, Slovakia
Lichtgitter CZ, Czech Republik
Lichtgitter Izgara, Turkey
Lichtgitter Bulgaria, Bulgaria
Lichtgitter Romania, Romania
Qatar Gratings and Road Bar-
riers, Qatar

Representatives

In addition, the Lichtgitter-
Group has further representa-
tives worldwide.

www.lichtgitter.de

Head Office Stadtlohn

Lichtgitter Gesellschaft mbH
Siemensstraße 1
D-48703 Stadtlohn

T + 49. 25 63. 911-0
F + 49. 25 63. 911-163

info@lichtgitter.de

Works Sulz

Lichtgitter Gesellschaft mbH
Bahnhofstraße 76
D-72172 Sulz Neckar

Works Blumberg

Lichtgitter Gesellschaft mbH
Schönower Straße 6
D-16306 Casekow-Blumberg

Lichtgitter GFK

Lichtgitter GFK GmbH & Co. KG
Siemensstraße 1
D-48703 Stadtlohn

T + 49. 25 63. 911-203
F + 49. 25 63. 911-222

info@lichtgitter.de